

# **CruiseCommand 785CE-GT Operation and Installation Manual**

MM4330-GT Rev.- 6/04

(This manual is used in conjunction with MM14330-I)



# SW13867.1C

## Table of Contents

Table of Contents .....	TOC-1
Revisions List .....	TOC-2
CruiseCommand with Governed Electric Troll.....	1-1
<b>1</b>	<b>DESCRIPTION: - - - - - 1-1</b>
<b>2</b>	<b>INSTALLATION REQUIREMENTS - - - - - 1-2</b>
2-1	Required Parts: . . . . . 1-2
<b>Table 1-1:</b>	<b><i>Governed Troll Required Parts</i>..... 1-2</b>
2-2	Speed Sensor and Pulser Wrap Installation: . . . . . 1-2
Figure 1-1:	Speed Sensor . . . . . 1-2
Figure 1-2:	Pulser Wrap . . . . . 1-2
Figure 1-3:	Speed Sensor Flats Orientation . . . . . 1-2
Figure 1-4:	View of Propeller Shaft, Speed Sensor, Mounting Bracket, and Pulser Wrap . . . . . 1-2
<b>3</b>	<b>SETUP AND ADJUSTMENTS - - - - - 1-3</b>
3-1	FUNCTION CODES: . . . . . 1-3
<b>Table 1-2:</b>	<b><i>Governed Troll Function Codes</i>..... 1-3</b>
3-2	FUNCTION CODE DESCRIPTIONS: . . . . . 1-3
<b>3-2.1</b>	<b><i>Function Code J0 – Governed Troll Engine Idle Frequency</i> . . . . . 1-3</b>
Figure 1-5:	CruiseCommand Processor Speed Sensor Connections without Junction Box . . . . . 1-3
<b>3-2.2</b>	<b><i>Function Code J1 – Governed Troll Minimum Percent</i> . . . . . 1-4</b>
<b>3-2.3</b>	<b><i>Function Code J2 – Governed Troll Maximum Percent</i> . . . . . 1-5</b>
<b>3-2.4</b>	<b><i>Function Code J3 – Governed Troll Range</i> . . . . . 1-6</b>
<b>3-2.5</b>	<b><i>Function Code J4 – Governed Troll Timeout</i> . . . . . 1-6</b>

# Revisions List

Rev	Date	Revision Description

785CE-GT**CruiseCommand with Governed Electric Troll**

785CE-GT is a basic CruiseCommand Processor with Governed Electric Troll as an additional feature. The following is the information required to utilize Governed Electric Troll. All other functions and features of CruiseCommand are described in the standard MM14330-I manual.

NOTE: STANDARD **OPEN LOOP** TROLL MUST BE PROGRAMMED WITH THE **L** FUNCTIONS AND FULLY OPERATIONAL PRIOR TO ATTEMPTING TO SET UP AND PROGRAM GOVERNED **CLOSED LOOP** TROLL. REFER TO THE CRUISECOMMAND INSTALLATION MANUAL, MM14330-I, FOR **L** PROGRAMMING.

**1 DESCRIPTION:**

In order to understand the operation of Governed Troll, also referred to as **Closed Loop Troll**, you must have a basic understanding of standard **Open Loop Troll** operation and control.

In a **Standard (Open Loop) Troll**, the Processor provides a gear mounted proportional solenoid a PWM (Pulse Width Modulation) signal. Based on the available clutch power, the PWM signal provides a set amount of current for a given Control Head lever position. The current delivered to the proportional solenoid is very accurate and repeatable. The current delivered to the proportional solenoid determines how much transmission oil pressure can be delivered to the clutch pack. The amount of pressure applied to the clutch pack determines if the clutch plates are making no contact, slipping or are fully locked up. In the perfect world, a set amount of current applied to the proportional solenoid will always result in a set propeller shaft speed. In the real world however, various items have an effect on this perfect world relationship. Items such as oil viscosity, oil temperature, engine loading, hard turns etc. can have a dramatic effect on the actual propeller shaft rpm for a given current. This is where the true advantage of Governed Troll is realized.

Initially, **Governed (Closed Loop)Troll** works in the same manner as standard troll. A preset amount of current (milliamps) is applied to a proportional solenoid for a given Control Head lever position. Governed Troll takes it a step further by monitoring the propeller shaft speed or closing the loop. Due to the shaft monitoring, the Processor can be programmed to a specific propeller shaft speed for a given Control Head lever position. This allows the Processor to automatically increase or decrease the amount of current being applied to the proportional solenoid in order to provide better propeller shaft rpm stability. The end result is a more consistent shaft rpm for a given lever position, since the Processor can make adjustments as oil temperature increases, the vessel turns, etc.

## 2 INSTALLATION REQUIREMENTS

### 2-1 REQUIRED PARTS:

Table 1-1: Governed Troll Required Parts

Part No.	Description	Quantity
S0416P0716X0300	Split Collar Pulser Wrap	1
16199	Speed Sensor, Pluggable	1
	Speed Sensor Mounting Bracket (included with the transmission)	1
16198-20/40P or 16198-15/40P	Tachometer Sensor Wire Harness	1

### 2-2 SPEED SENSOR AND PULSER WRAP INSTALLATION:

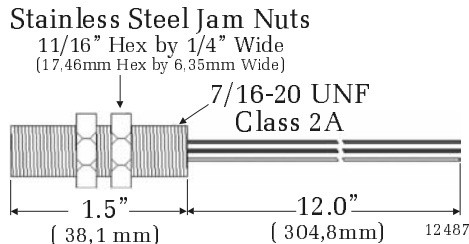

Figure 1-1: Speed Sensor

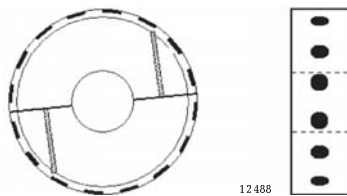

Figure 1-2: Pulser Wrap

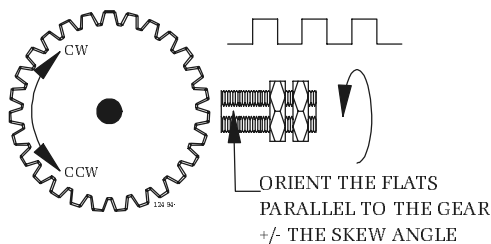

Figure 1-3: Speed Sensor Flats Orientation

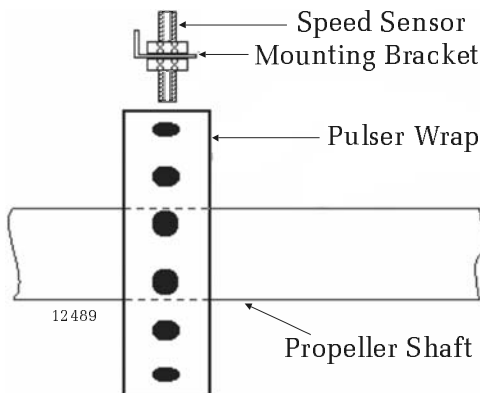

Figure 1-4: View of Propeller Shaft, Speed Sensor, Mounting Bracket, and Pulser Wrap

- A) Remove one of the Jam Nuts from the Speed Sensor. Refer to Figure 1-1:
- B) Insert the Speed Sensor into the hole of the Mounting Bracket supplied with the transmission.
- C) Reinstall the Jam Nut, but do not tighten at this point.
- D) The Pulser Wrap is shipped with four Allen-head screws holding the two halves together. Remove the screws so that the wrap is in two halves.
- E) Place the halves around the shaft in the proximity of the Speed Sensor.
- F) Replace the four screws in order to hold the halves together, but do not tighten.
- G) Position the Pulser Wrap on the Shaft so that the Speed Sensor is centered on the Wrap. Refer to Figure 1-4:
- H) Tighten down the four Allen-head screws to 5 foot pounds. After installation, a small gap between the two halves is normal.
- I) Adjust the Speed Sensor so that the flats are parallel to the pulser wrap and the air gap between the Sensor and the Pulser Wrap is no more than 0.2 inch (5,08mm). Refer to Figure 1-3:
- J) Tighten the Speed Sensor's Jam Nut.
- K) Care must be taken to ensure that the Speed Sensor is perpendicular (90 degree angle +/- 10 degrees) to the Pulser Wrap.
- L) Select a Tachometer Sensor Wire Harness of sufficient length to reach from the Speed Sensor's plug to the Processor.

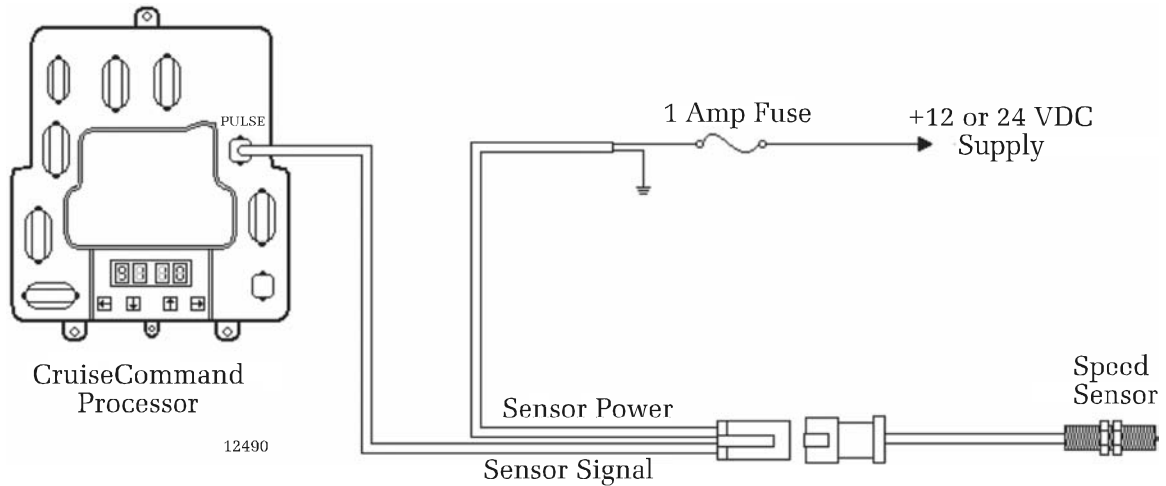

Figure 1-5: CruiseCommand Processor Speed Sensor Connections without Junction Box

- M) Select an available 12 or 24 VDC power source within the standard 40 foot length of power cable.
- N) Connect the Harness’ 3-Pin Plug into the Speed Sensor’s plug.
- O) Connect the Harness’ 4-Pin Plug into the Processor’s “Pulse” socket.
- P) Connect the Harness’ power cable to a 12 or 24 VDC supply through a 1 Amp Fuse.

### 3 SETUP AND ADJUSTMENTS

**NOTE:** THE STANDARD **OPEN LOOP** VERSION OF TROLL MUST BE SET UP AND THE OPERATION VERIFIED PRIOR TO CONNECTING AND PROGRAMMING GOVERNED TROLL. REFER TO THE ATTACHED MM14330-I INSTALLATION MANUAL SET UP PROCEDURES SECTION.

#### 3-1 **FUNCTION CODES:**

Table 1-2: Governed Troll Function Codes

FUNCTION CODE	FUNCTION NAME	DEFAULT VALUE	UNITS	VALUE RANGE OR OPTIONS
J0	Governed Troll Engine Idle Frequency	0	1 Hertz	1 to 9999
J1	Governed Troll Minimum Percent	30%	1%	1 to Maximum Percent
J2	Governed Troll Maximum Percent	70%	1%	Minimum Percent to 100
J3	Governed Troll Range	0	0.1%	0 to 20.0 (0 to 20%)
J4	Governed Troll Timeout	1.0	100 msec.	0.1 to 20.0 seconds

#### 3-2 **FUNCTION CODE DESCRIPTIONS:**

##### **3-2.1 Function Code J0 – Governed Troll Engine Idle Frequency**

The value entered here represents the speed of the Propeller Shaft (Output Shaft) at Idle. There are two methods of obtaining the appropriate value. They are as follows:

##### A) **H0** Function (Method 1)

1. Scroll Up or Down to the **H0** Function Code on the display.

2. Depress the Left and Right Arrow push buttons until the **H0xx** begins blinking, then release.
3. Depress the Down Arrow push button one time.
4. Start the engine and command Idle Ahead without Troll.
5. Record the frequency displayed on the LED Display.
6. Return the Control Head to the Neutral/ Idle position and shut down the engine.
7. Repeat steps 1 thru 6 as needed, for twin or more screw applications.

B) Calculate (Method 2)

1. Record the engine's Idle rpm \_\_\_\_\_.
2. Record the transmission's reduction ratio \_\_\_\_\_.
3. Record the number of Pulses Per Revolution (PPR) for the Output Shaft Sender \_\_\_\_\_.
4. Divide the Output Shaft by the Input Shaft's ratio's. i.e. 2:1 ratio = 0.50 \_\_\_\_\_.
5. Multiply engine Idle rpm by the result of step 4. i.e.  $600 \times 0.50 = 300$  \_\_\_\_\_.
6. Multiply results of steps 3 and 5. i.e.  $32 \text{ PPR} \times 300 = 9600$  \_\_\_\_\_.
7. Divide results of step 6 by 60. i.e.  $9600 / 60 = 160$  \_\_\_\_\_.
8. Program the Value obtained in step 7 into the **J0** Function.

Regardless of which of the above methods was used, the frequency representing the Propeller Shaft must be entered into Function Code **J0**. This base value is used by the Processor to calculate Troll Minimum and Maximum Percents.

Idle Frequency Programming

- A) Press the Up or Down Arrow push button until Function Code **J0** is displayed.
- B) Depress the Left and Right Arrow push buttons simultaneously until **J0** begins to blink slowly.
- C) Press the Up or Down Arrow push button until the value obtained in Method 1 or Method 2 is reached.
- D) Enter the new value into memory by simultaneously depressing the Left and Right Arrow push buttons.

**3-2.2**

**Function Code J1 – Governed Troll Minimum Percent**

The value entered determines the percentage of **Governed Troll Engine Idle Frequency (J0)** which the Processor commands and maintains for minimum propeller shaft rotation during closed loop troll operation. This function should be set to the same value used in **Open Loop Troll**. If 30% was used set in Open Loop, stay with 30%.

**Example:**

Using the scenario where the engine Idle rpm is 600, with a reduction ratio of 2:1, the normal propeller shaft rpm would be 300. If the default value of 30% was used, the minimum propeller shaft speed during troll would be 30% of 300 rpm, or 90 rpm.

This Function allows any value from **0** to **Governed Troll Maximum Percent (J2)** to be entered. However, our experience has shown controlling the shaft rotation when below 30% is difficult, if not impossible in some cases.

**Governed Troll Minimum Percent Programming:**

- A) Press the Up or Down Arrow push button until Function Code **J1** is displayed.
- B) Depress the Left and Right Arrow push buttons simultaneously until **J1** begins to blink slowly.
- C) Press the Up or Down Arrow push button until the desired value is reached.
- D) Enter the new value into memory by simultaneously depressing the Left and Right Arrow push buttons.

**3-2.3****Function Code J2 – Governed Troll Maximum Percent**

The value entered determines the percentage of **Governed Troll Engine Idle Frequency (J0)** which the Processor commands and maintains for maximum propeller shaft rotation during **Closed Loop Troll** operation. This function should be set to the same value used in **Open Loop Troll**. If 70% was set in Open Loop, stay with 70%.

**Example:**

Using the scenario where the engine Idle rpm is 600, with a reduction ratio of 2:1, the normal propeller shaft rpm would be 300. If the default value of 70% was used, a maximum propeller shaft speed during troll would be 70% of 300 rpm, or 210 rpm.

This Function allows any value from the programmed value of **Governed Troll Minimum Percent (J1)** to 100% to be entered. However, our experience has shown controlling the shaft rotation above 70% to be difficult, if not impossible without “chattering” or fully locking up the clutch plates in many cases.

**Governed Troll Maximum Percent Programming:**

- A) Press the Up or Down Arrow push button until Function Code **J2** is displayed.
- B) Depress the Left and Right Arrow push buttons simultaneously until **J2** begins to blink slowly.
- C) Press the Up or Down Arrow push button until the desired value is reached.
- D) Enter the new value into memory by simultaneously depressing the Left and Right Arrow push buttons.

**3-2.4 Function Code J3 – Governed Troll Range**

This value determines the systems expected accuracy at **Governed Troll Minimum Percent** and **Governed Troll Maximum Percent**.

Example:

This example is written assuming a solenoid current of 200 mA is required for minimum pressure. (The Minimum Troll shaft rotation is set to 90 rpm), and 300 mA is required for maximum pressure. (Maximum Troll shaft rotation set to 210 rpm). If the **Governed Troll Range (J3)** were set to **1.0** (1.0% of current range, 300 mA.- 200 mA. = 100 mA.), the current at Maximum Troll could vary from 299 mA. to 301 mA. in order to maintain the propeller shaft rpm at 90. Once the current limit range is reached, no further adjustments are made unless the target rpm once again falls within the current range or a change in the troll command is given.

Governed Troll Range Programming:

- A) Press the Up or Down Arrow push button until Function Code **J3** is displayed.
- B) Depress the Left and Right Arrow push buttons simultaneously until **J3** begins to blink slowly.
- C) Press the Up or Down Arrow push button until the desired value is reached.
- D) Enter the new value into memory by simultaneously depressing the Left and Right Arrow push buttons.

**3-2.5 Function Code J4 – Governed Troll Timeout**

The value entered determines how often changes are made to the current (milliamps) supplied to the proportional solenoid when the actual propeller shaft rpm does not match the values programmed into **Governed Troll Minimum Percent** and **Governed Troll Maximum Percent**.

Governed Troll Timeout Programming:

- A) Press the Up or Down Arrow push button until Function Code **J4** is displayed.
- B) Depress the Left and Right Arrow push buttons simultaneously until **J4** begins to blink slowly.
- C) Press the Up or Down Arrow push button until the desired value is reached.
- D) Enter the new value into memory by simultaneously depressing the Left and Right Arrow push buttons.